

REVISIONS				
REV	DATE	DESCRIPTION	ECO	BY
A	06-04-04	PRODUCTION RELEASE	11137	FJM
B	07-21-04	ADDED SHEET TWO, INSTALLATION & NOTE FIVE. CHANGED KEY FROM 1.38 TO 1.50".	11146	FJM
C	09-23-04	NOTE 1F IS 1.0, WAS 1.15.	11173	DSN
D	05-03-06	CHANGED DIM .04 TO .15.	11442	FJM
E	07-18-07	UPDATE HOLE IS: 2X ϕ .136 (DRILL BIT #29), WAS: 2X TAP 8-32 UNF-2B.	11643	RKL
F	05-07-08	1. SHT 2: UPDATE NOTE 5. TOTAL DYNAMICS VALUE, WAS: 4 gr-in PER PLANE; IS: 1 gr-in. ADD: BALANCING SHOULD BE WITH HALF KEY. 2. SHT 2: REMOVE ID/SERIAL TAG.	11904	ME
G	08-19-09	ADD NOTES 7 AND 8.	12251	SJK

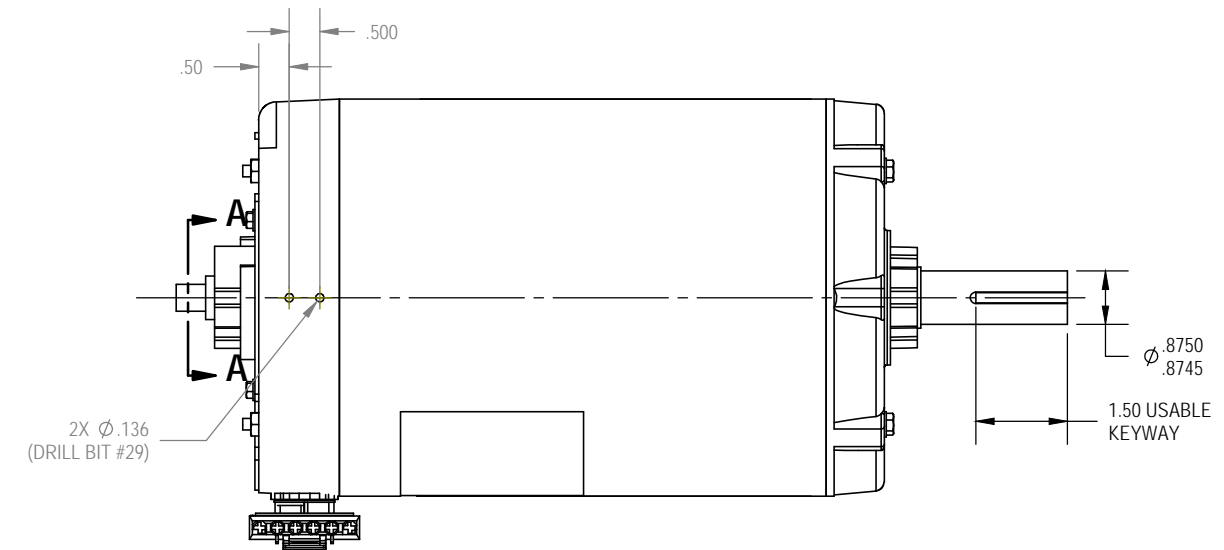

WIRES CONFIGURATION (LOW VOLTAGE)				
CONN PIN	LEADS	WIRE COLOR	WIRE GA	LINE
1	9 & 3	BLACK (T3)	#14	3
2	7 & 1	BLACK (T2)	#14	2
3	8 & 2	BLACK (T1)	#14	1
4	--	--	--	N/A
5	THERMOSTAT	BLACK (P1)	#14	N/A
6	THERMOSTAT	BLACK (P2)	#14	N/A

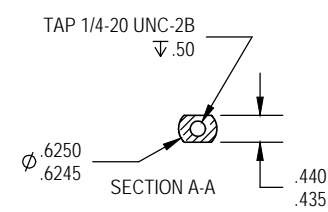
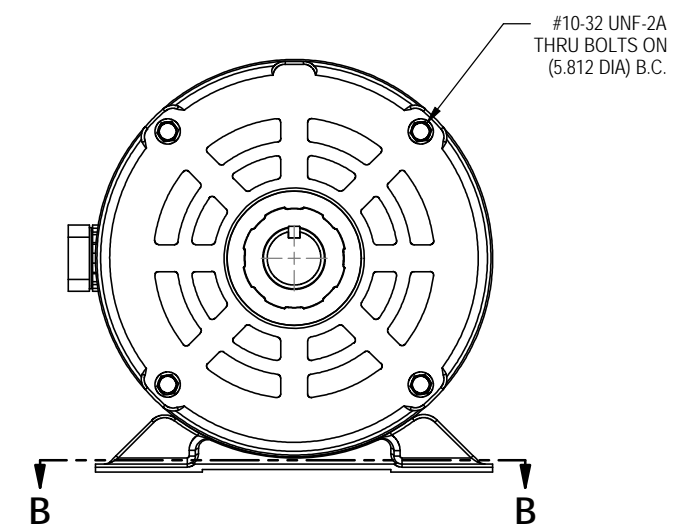
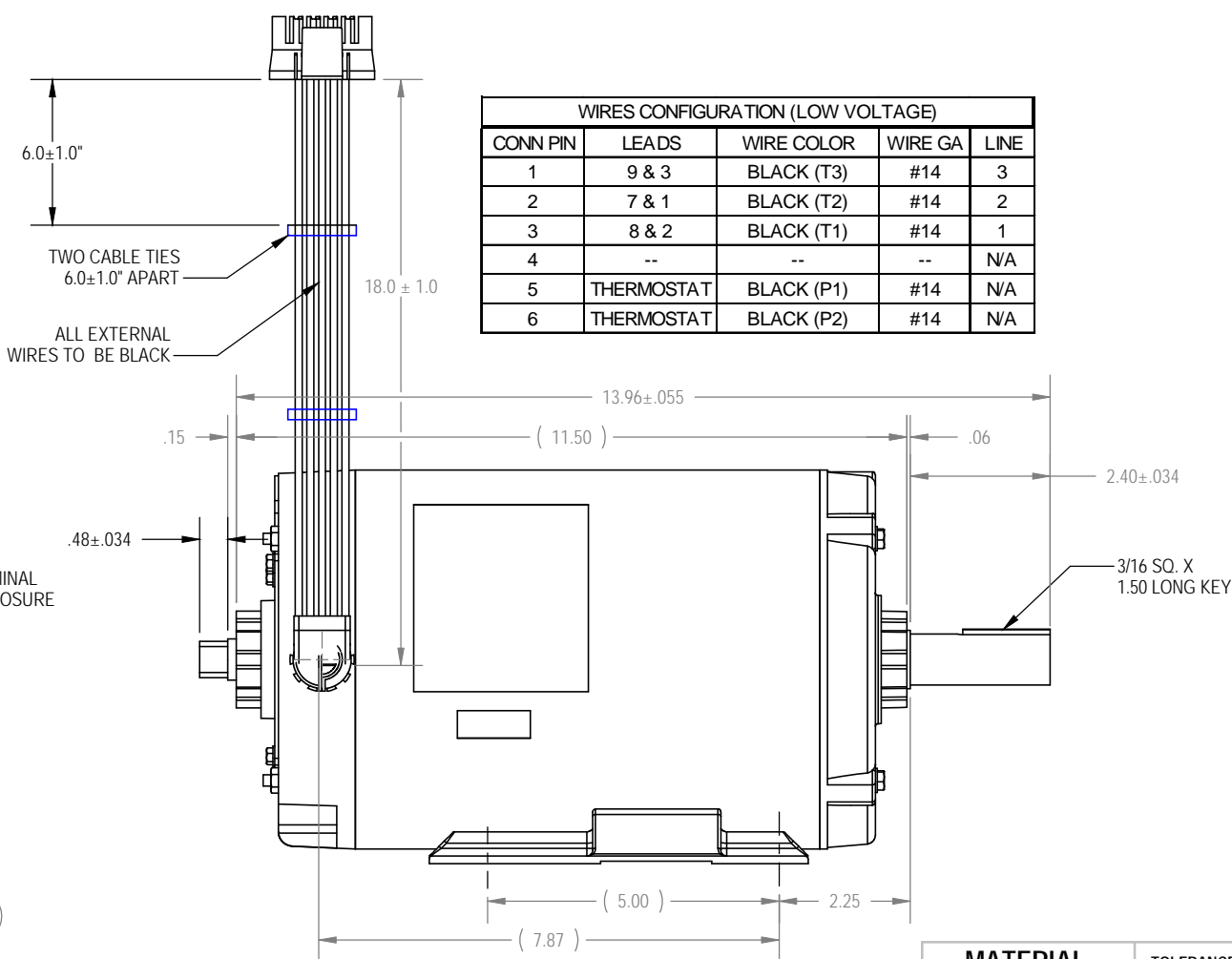
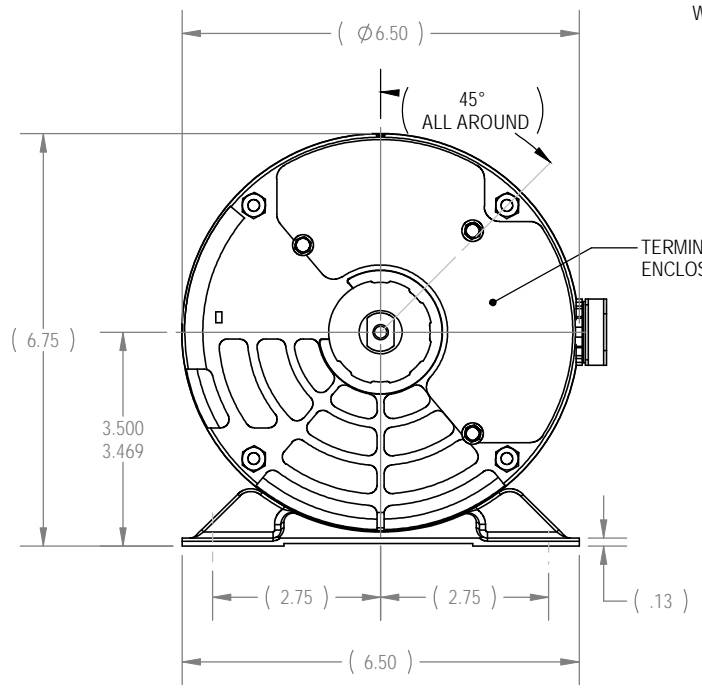
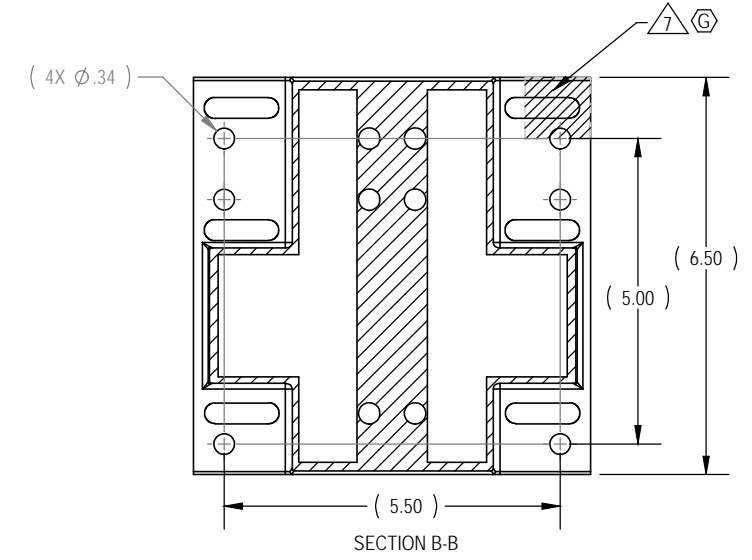

**DOCUMENT STATUS:
RELEASE**

NOTICE OF PROPRIETARY INFORMATION
THIS DOCUMENT SHALL NOT BE REPRODUCED NOR SHALL THE INFORMATION CONTAINED HEREIN BE USED BY OR DISCLOSED TO OTHER EXCEPT AS EXPRESSLY AUTHORIZED BY UNISEN

MATERIAL SEE NOTES	TOLERANCES UNLESS OTHERWISE SPECIFIED		UNISEN, INC. DBA STAR TRAC 14410 Myford Road Irvine CA 92606	
	X.XXX = ± .010	ANGLES = ± 2°	PART NO 260-0934	REV G
X.XX = ± .030	FRACTIONS = ± 1/32	TITLE MOTOR, AC INDUCTION, 230V		
FINISH SEE NOTES	DRAWN FJM	DATE 01-14-04	SCALE: 1:3 SHEET 1 OF 2 SHEET SIZE: B	
	CHECKED			
	APPROVED			
	U.O.M.	INCH		

NOTES:
1. SEE SHEET TWO

NOTES:

1. ELECTRICAL SPECIFICATIONS:

- a) RATING: 5HP SPL
- b) VOLTS: 230 AC
- c) HZ: 60
- d) AMPS: 6.0
- e) RPM: 1,745 (5,400 MAX)
- f) SF: 1.0
- g) INSULATION CLASS: F

2. MECHANICAL SPECIFICATIONS:

- a) BEARINGS TO BE PRELUBRICATED.
- b) MOTOR TYPE: SCM
- c) MOTOR FRAME: P145T
- d) MOTOR FORM: K
- e) APPROX. NET WGT: 39 LBS.

3. MOTOR MANUFACTURER: A.O. SMITH, P/N 114501 (DWG NO. 18745401).

4. MOTOR PERFORMANCE AND WINDING PARAMETERS SHALL BE WITHIN THE MFG. TOLERANCES OF A.O. SMITH SAMPLE #0345747A.

5. BALANCE MOTOR TO A.O. SMITH PC1449 BALANCE STANDARD.

(Balance motor 1 gram-inch per plane or less @ 2,000 rpm
Balancing should be with 1/2 key).

6. CALIBRATE BALANCING MACHINE AT LEAST ONCE A WEEK.

7. MASK AREA FOR ELECTRICAL GROUNDING PURPOSES. Ⓞ

8. TAPE MOTOR PULLEY KEY TO SUPPLIER LABEL BEFORE PACKAGING OF MOTOR. Ⓞ

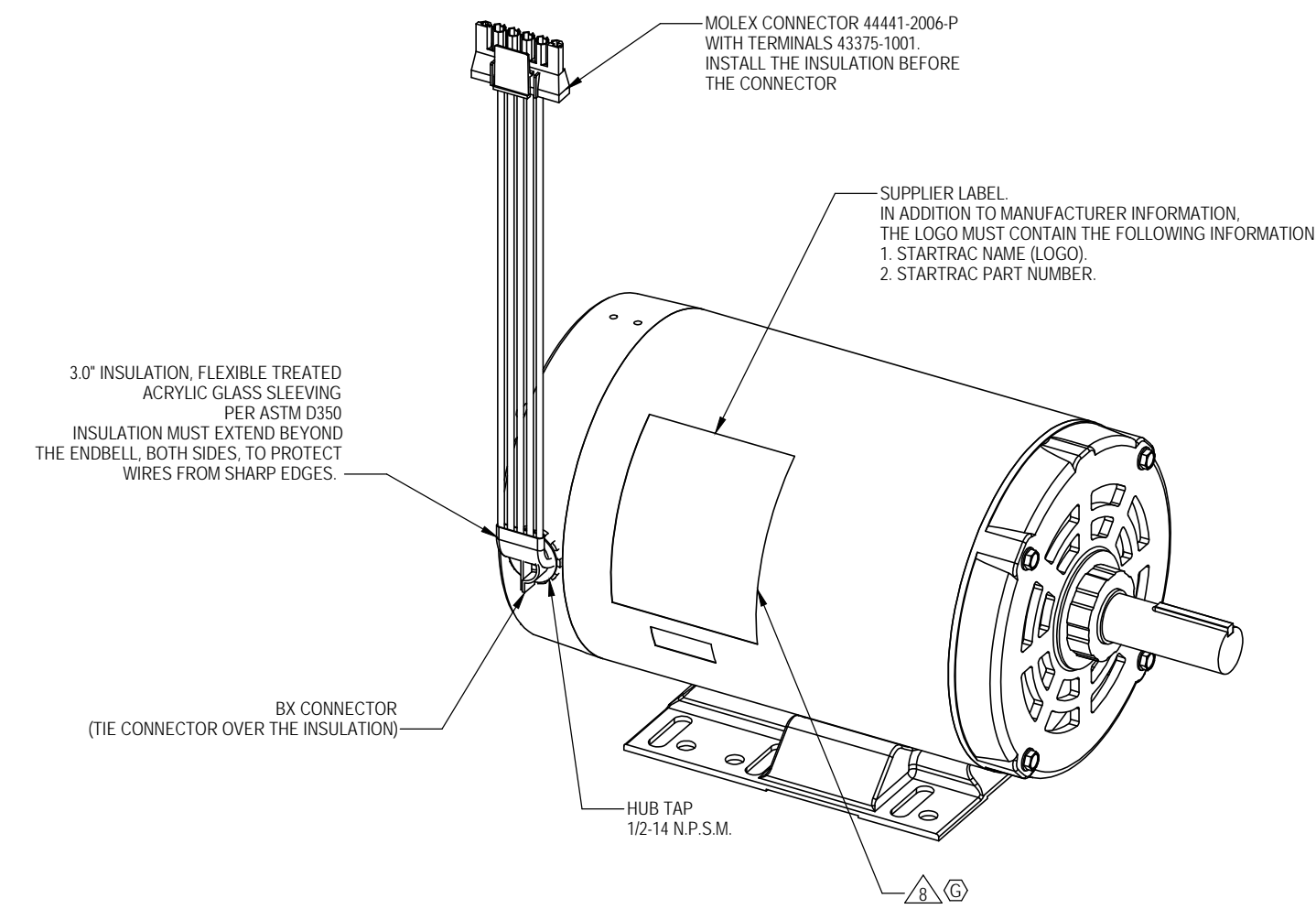
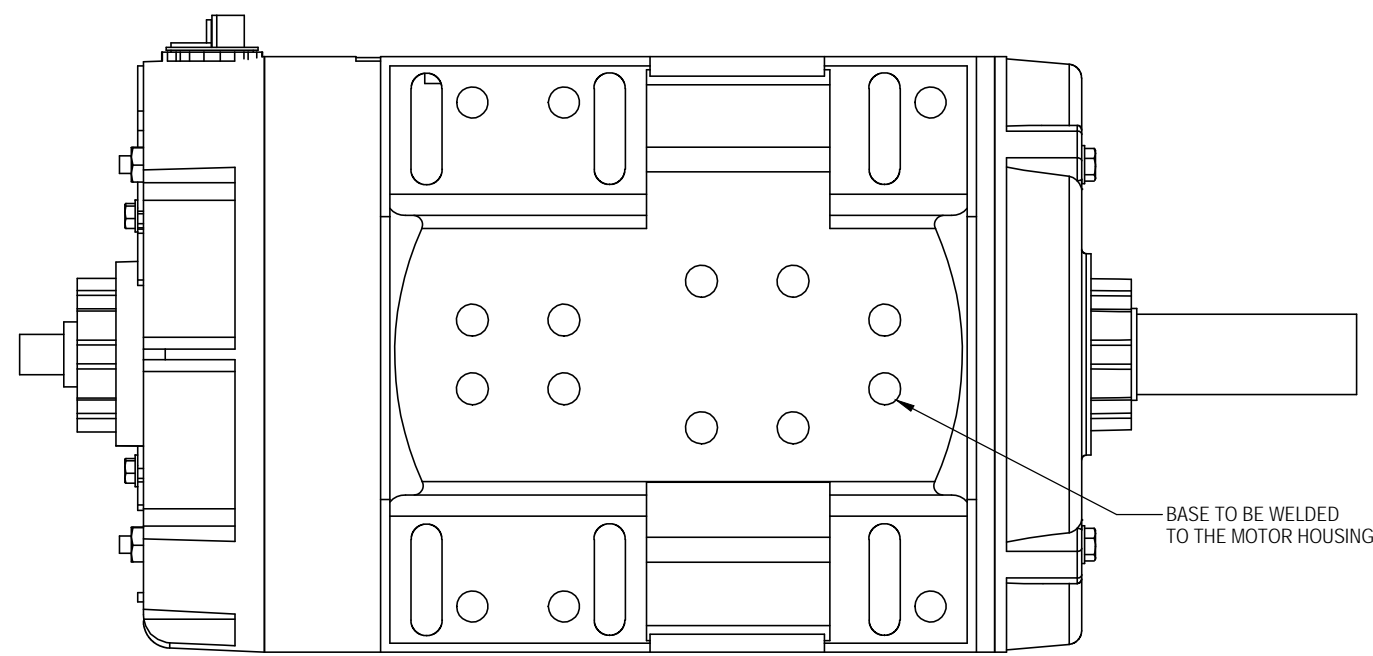

SUPPLIER LABEL:
IN ADDITION TO MANUFACTURER INFORMATION,
THE LOGO MUST CONTAIN THE FOLLOWING INFORMATION:
1. STARTRAC NAME (LOGO).
2. STARTRAC PART NUMBER.

NOTICE OF PROPRIETARY INFORMATION

THIS DOCUMENT SHALL NOT BE REPRODUCED NOR SHALL THE INFORMATION CONTAINED HEREIN BE USED BY OR DISCLOSED TO OTHER EXCEPT AS EXPRESSLY AUTHORIZED BY UNISEN

UNISEN, INC. DBA		14410 Myford Road Irvine CA 92606	
PART NO	260-0934	REV	G
TITLE	MOTOR, AC INDUCTION, 230V		
SCALE: 1:3	SHEET 2 OF 2	SHEET SIZE: B	